

CHARACTERISTICS			
Nominal Voltage		6V	
Nominal Capacity (20 hour rate)		12Ah	
Capacity 25°C	10 hour rate (9.0A)	11.4Ah	
	5 hour rate (15.9A)	10.7Ah	
	1 hour rate (55.4A)	7.92Ah	
Internal Resistance		Full Charged Battery 25°C	≤12mΩ
Capacity affected by Temperature (10 hour)	40°C	102%	
	25°C	100%	
	0°C	85%	
	-15°C	65%	
Self-Discharge 25°C Capacity	after 3 month storage	90%	
	after 6 month storage	80%	
	after 12 month storage	62%	
Charge (Constant Voltage) 25°C	Float	Initial Charging Current Less than 3.6A Voltage 6.8-6.9V	
	Cycle	Initial Charging Current Less than 3.6A Voltage 7.2-7.5V	

PACKAGING		
Battery Dimensions	Length	151mm
	Width	50mm
	Height	95mm
	Total Height	101mm
Quantity Per Box	10 pcs per box	
Net weight Per Box	17.2kg	
Gross Weight	18kg	

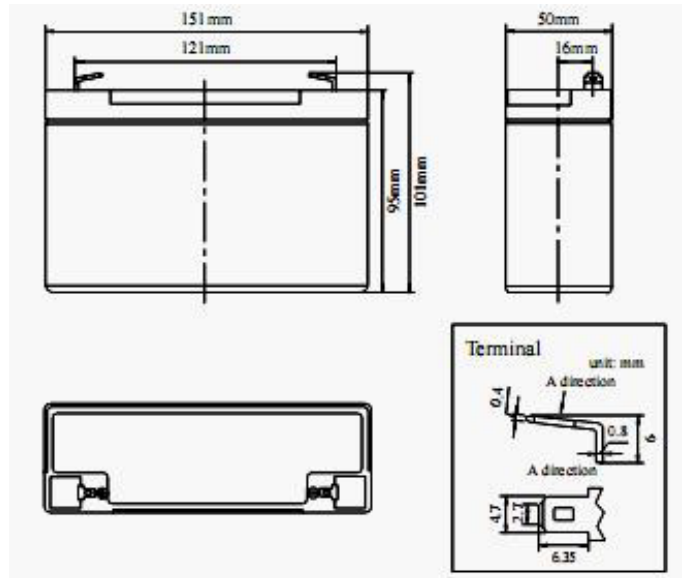

Discharge Constant Current per Cell (Amperes at 25°C)

F.V/Time	30min	1h	2h	5h	10h	20h
1.60V	13.20	7.92	4.95	2.26	1.26	0.66
1.65V	12.96	7.78	4.86	2.22	1.23	0.65
1.70V	12.72	7.63	4.77	2.18	1.21	0.64
1.75V	12.48	7.49	4.68	2.14	1.19	0.62
1.80V	12.00	7.20	4.50	2.06	1.14	0.60

PERFORMANCE CHARACTERISTICS

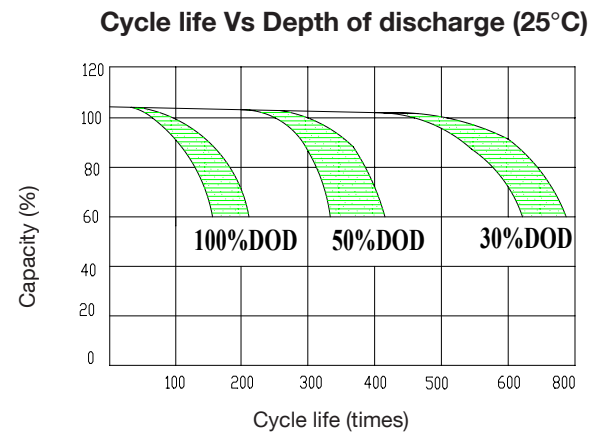
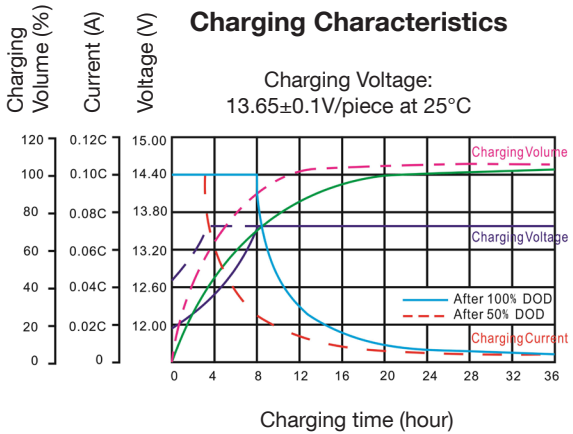

Two Great Stores to choose from...

7 Cemetery Rd, Mackay QLD 4740 | Phone 07 4957 6123

Unit 16, 547 Woolcock St, Mt Louisa, Townsville QLD 4814 | Phone 07 4774 7344

Temperature effect on designed float life

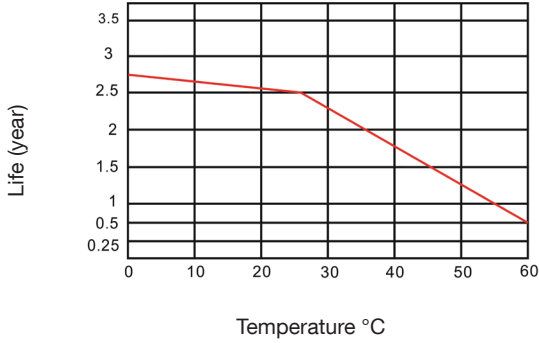
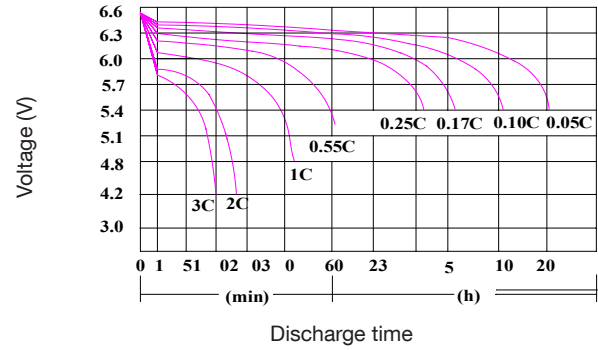
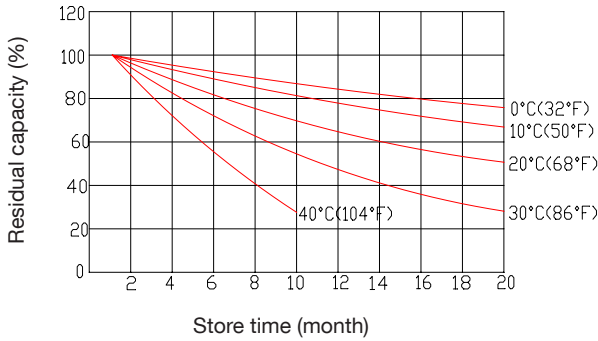
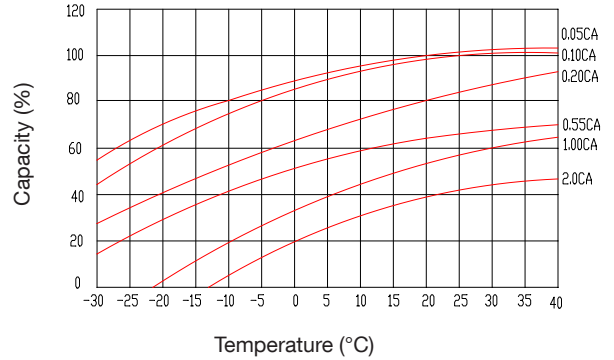
 Float charging Voltage:
 $13.65 \pm 0.01V/\text{piece}$ at 25°C

Discharge characteristics (25°C)

Temperature effect on battery self-discharge

Temperature effect on capacity

BATTERY CONSTRUCTION

Component	Positive plate	Negative plate	Container	Cover	Safety valve	Terminal	Separator	Electrolyte
Raw material	Lead dioxide	Lead	ABS	ABS	Si-Rubber	Copper	Fiberglass	Sulfuric acid

Two Great Stores to choose from...

 7 Cemetery Rd,
 Mackay QLD 4740
 Phone 07 4957 6123

 Unit 16, 547 Woolcock St,
 Mt Louisa, Townsville QLD 4814
 Phone 07 4774 7344