

### Technical Information

The Delkor 100D-730 is a custom military-spec battery designed for army tanks, Unimogs and other military / off-road vehicle applications.

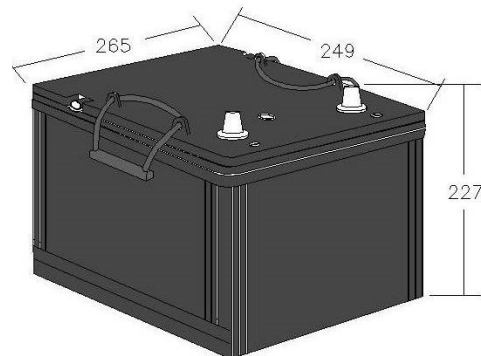

### Features and Benefits

- Renowned Delkor quality
- Sealed Maintenance-Free
- Unique design for specific Unimog and military applications
- Strong, durable wrought grid plate design
- Lock-bonded elements for added durability and strength

### Applications

- Unimog (Mercedes-Benz)
- Army tanks
- Military applications
- Oka 4WD truck
- Custom applications

### Technical Specifications

<b>Battery Type:</b>	Sealed Maintenance-Free	<b>Container Material / Colour:</b>	Polypropylene / Black
<b>Voltage:</b>	12	<b>Lid Type / Colour:</b>	Sealed / Black
<b>Capacity (@20hr rate):</b>	100	<b>Plate Type:</b>	Commercial-grade Lead-Calcium + Tin
<b>Cold Cranking Amps -18°C, SAE:</b>	730	<b>Separator Type:</b>	PVC Envelope
<b>Cold Cranking Amps – 0 Deg. C</b>	850	<b>Anti-Vibration:</b>	Lock-bonded plate elements
<b>Reserve Capacity:</b>	185 Min.	<b>Assembly Layout:</b>	RHP
<b>Overall Dimensions:</b>	265L x 249W x 227TH	<b>Terminal Type:</b>	SAE
<b>Wet Battery Weight:</b>	25.5kg	<b>BCI Group:</b>	6TN

**WARRANTY:** 12 MONTHS.

Normal Delkor commercial battery warranty conditions apply. Refer to Delkor warranty statement for more information.