



www.a1batterypro.com.au

DC250-6 GROUP GC2



CYCLING CAPACITY

20 Hour Rate **250 Amp Hours**

RESERVE CAPACITY

Reserve @25 AMPS **531 Minutes** Reserve @75 AMPS **135 Minutes**

ELECTRICAL SPECIFICATIONS

Nominal Voltage	6 Volt
C100	275AH
C20	250AH
C10	229AH
C5	204AH
CCA	960
CA or MCA	1160
HPCA	2000 Amps
Internal Resistance	1.6m Ω

MECHANICAL SPECIFICATIONS

Group Size	GC2	
Terminal Type	AP	
Terminal Torque	See reverse side	
Height (w/ terminal)	11.14"	283mm
Height (case only)	10.47"	266mm
Width	7.13"	181mm
Length	10.31"	262mm
Weight	76.1 lbs.	34.5 kg
Case Type	ABS Plastic - Flame Res. Rating UL94-HB	

DISCHARGE TABLE (Constant Current)

Time	Amps	Rate
20hr	12.5	0.05CA
10hr	22.9	0.10CA
8hr	27.2	0.13CA
5hr	40.8	0.20CA
3hr	56.6	0.33CA
2hr	78.5	0.50CA
1hr	136	1.00CA

DISCHARGE PROFILE (Constant Current)

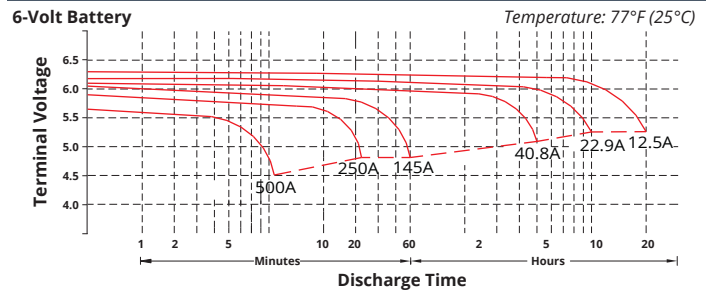

- All listed ratings are @ 100% SoC, T=77°F (25°C), 1.75VPC unless otherwise specified.
 - Specifications listed are for estimation purposes only. Battery performance can vary depending on application. Battery design subject to change.

BATTERY & TERMINAL DIMENSIONS (All units shown in mm)

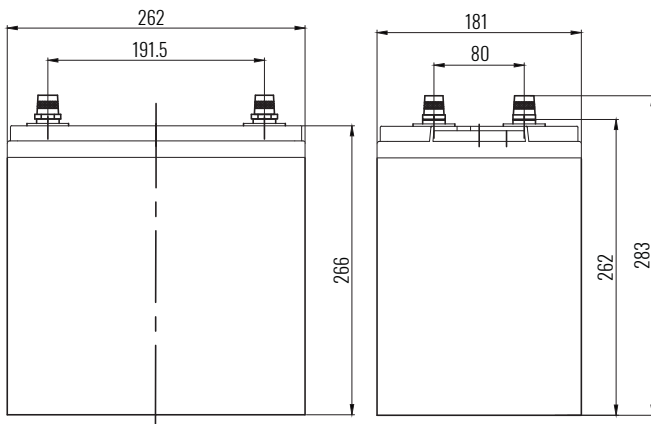

Battery bank spacing required, 12.5mm (1/2" inch) minimum

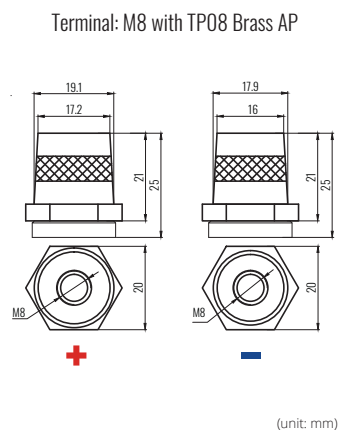

(unit: mm)

Two Great Stores to choose from...

7 Cemetery Rd,
Mackay QLD 4740
Phone 07 4957 6123

Unit 16, 547 Woolcock St,
Mt Louisa, Townsville QLD 4814
Phone 07 4774 7344

PREMIUM DEEP CYCLE SERIES | DEEP CYCLE AGM

TEMPERATURE vs CAPACITY

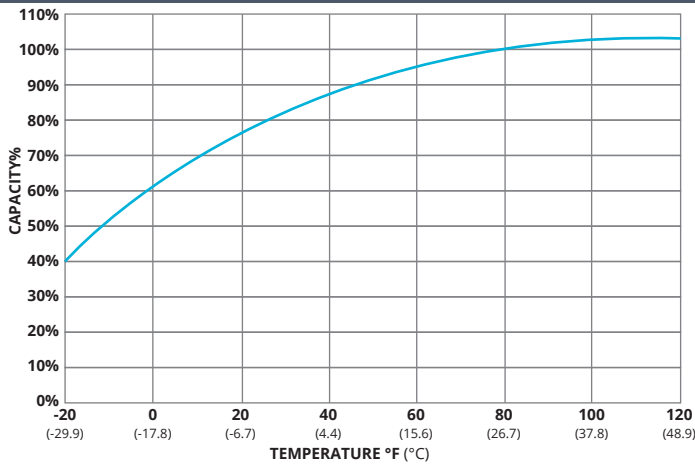

STATE of CHARGE (SOC) vs OPEN CIRCUIT VOLTAGE (OCV)

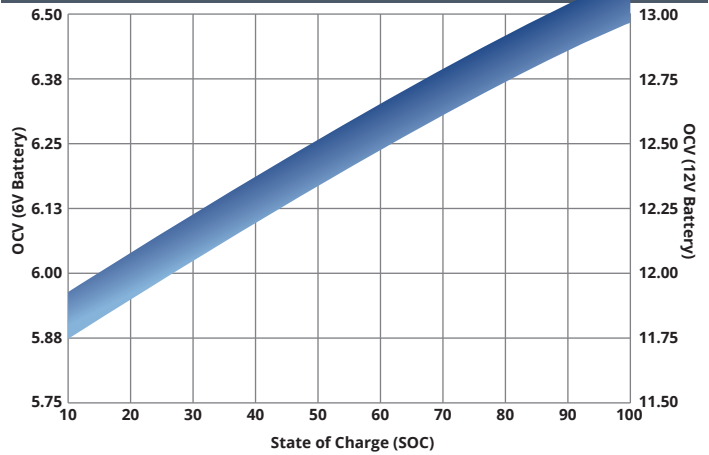

CYCLE LIFE vs DEPTH of DISCHARGE (DOD)

*(Based on BCI Testing @ 2-hr Rate)

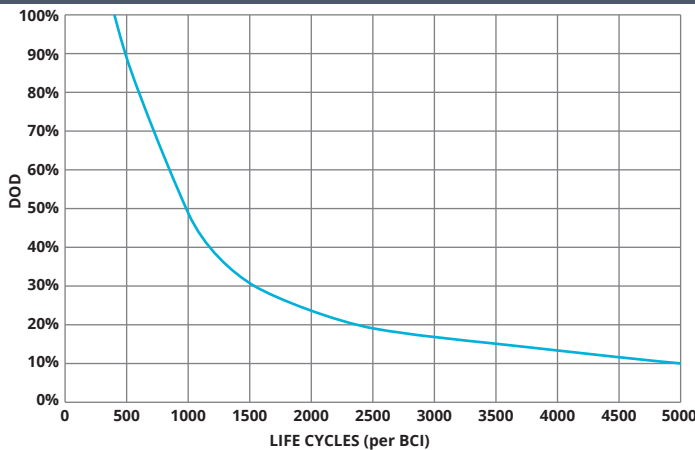

SELF DISCHARGE vs TIME/TEMPERATURE

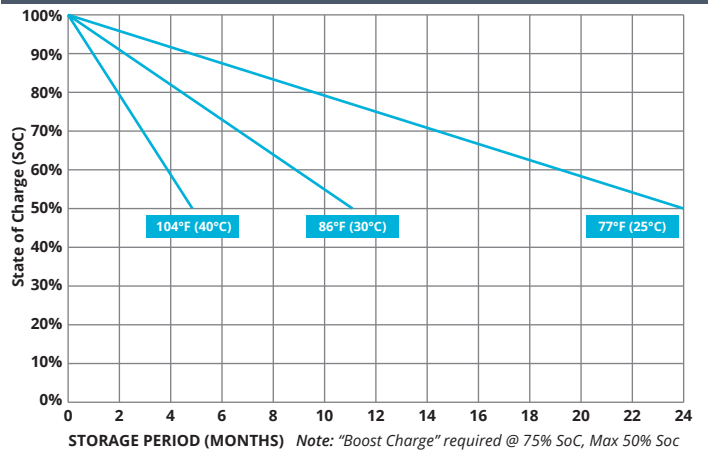

TEMPERATURE RANGE SPECIFICATIONS

Condition	Recommended	Maximum	Recommended	Maximum
Storage	5°F to 122°F	-40°F to 160°F	-15°C to 50°C	-40°C to 71°C
Operation	5°F to 104°F	-40°F to 160°F	-15°C to 40°C	-40°C to 71°C
Charge with TC	5°F to 122°F	-40°F to 160°F	-15°C to 50°C	-40°C to 71°C
Charge w/o TC	32°F to 104°F	5°F to 122°F	0°C to 40°C	-15°C to 50°C

*TC= Temperature Compensation

CHARGE VOLTAGES

Charge Stage	Battery Voltages			
	6V	12V	24V	48V
Bulk	7.35V	14.7V	29.4V	58.8V
Absorption	7.35V	14.7V	29.4V	58.8V
Float	6.8V	13.6V	27.2V	54.6V

TC Factor: (-2mV/°F/cell) or (-4mV/°C/cell)

TERMINAL TORQUE SPECS (applicable values are highlighted)

M6, AP	M8	M10	M6M (Stud)	M8M (Stud)	M10M (Stud)	3/8" Stud	FR45	TP06 (AP)	TP08/TP68 (AP)
4.1-5.8ft-lbs	7.1-7.9ft-lbs	9.6-12ft-lbs	3.3-4.6ft-lbs	4.9-6.3ft-lbs	7.7-9.6ft-lbs	8.9-12ft-lbs	5.8-7.4ft-lbs	3.3-4.6ft-lbs	50-70ft-lbs
50-70lbs-in	85-95lbs-in	115-141lbs-in	40-56lbs-in	58-75lbs-in	92-115lbs-in	106-150lbs-in	70-90lbs-in	40-56lbs-in	63-83lbs-in
5.6-7.9Nm	9.6-10.7Nm	13-16Nm	4.5-6.3Nm	6.6-8.5Nm	10.4-13Nm	12-16.9Nm	7.9-10.1Nm	4.5-6.3Nm	7.1-9.4Nm

Two Great Stores to choose from...

7 Cemetery Rd,
Mackay QLD 4740

Phone 07 4957 6123

Unit 16, 547 Woolcock St,
Mt Louisa, Townsville QLD 4814

Phone 07 4774 7344