



Batterypro

www.a1batterypro.com.au

ES633

Issue Date: 08/11/2018

Predator

AGM BATTERIES

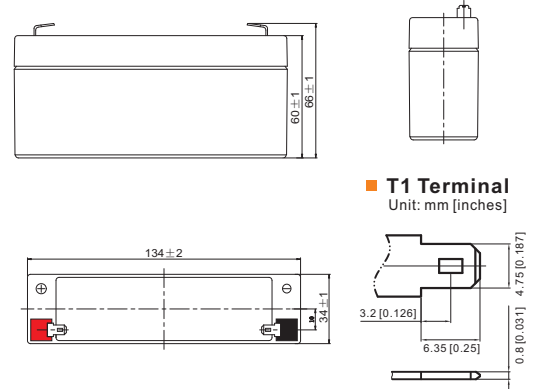

Specifications:

Model: ES633	
Nominal Voltage	6V
Rated Capacity	
20 Hour Rate (0.165A to 5.4V)	3.3Ah
Hourly rate conversion capacity	
10 Hour Rate (0.298A to 5.4V)	2.98Ah
5 Hour Rate (0.538A to 5.25V)	2.69Ah
1 Hour Rate (1.94A to 4.8V)	1.94Ah
Dimension and Weight	
Length	134±2mm
Width	34±1mm
Height	60±1mm
Total Height	66±1mm
Weight	0.67Kg
Casing Material	ABS
Self discharge Rate (25°C)	≥91% /3 month
Internal Resistance	Fully charged Battery ≤ 28.0mΩ
Operating Temperature Range	
Discharge	-15°C (5°F) ~ 50°C (122°F)
Charge	0 °C (32°F) ~ 40 °C (104°F)
Storage	-15°C (5°F)~40°C (104°F)
Charging Methods	
Float Use	6.75V~6.90V(25°C), Compensation co-efficient-3mv/cell/°C
Cycle Use	7.20V~7.50V(25°C), Compensation co-efficient-5mv/cell/°C
Max Charge Current	0.25C(A)
Applications:	Solar power, Wind power, Telecom systems, UPS

Discharge Characteristics

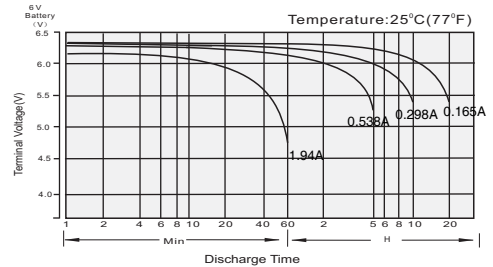

Cycle Life in Relation to Depth of Discharge

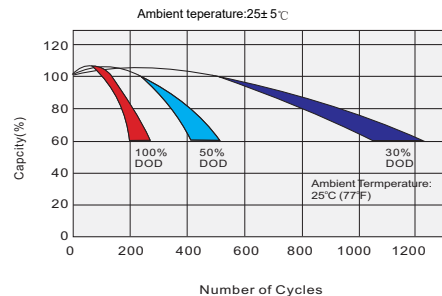

Two Great Stores to choose from...

7 Cemetery Rd,
Mackay QLD 4740

Phone 07 4957 6123

Unit 16, 547 Woolcock St,
Mt Louisa, Townsville QLD 4814

Phone 07 4774 7344