

12V

1750A

GBX55



EXTREME POWER. ULTRASAFE® LITHIUM JUMP STARTER.™

GAS & DIESEL

7.5L GAS & 5.0L DIESEL.
Designed for gas engines up to 7.5 liters and diesel engines up to 5.0 liters for small diesel cars, SUVs, boats, trucks, ATVs, motorcycles and more.

0% TO BOOST

FAST CHARGE.
Boost X is equipped with USB-C technology that, combined with power delivery, gives you lightning-fast recharges. Completely recharge Boost X in less time, or go from 0% to jump starting in just 5-minutes of charge.



60-SECOND TIMEOUT.
An automatic power conservation feature. Start vehicle within 60 seconds. After the 60-second timeout is complete, the unit must be powered off, then back on, to initiate a new jump-start sequence.

2.0

ULTRASAFE 2.0.
We took our UltraSafe technology and made it better. It's still our simple, mistake-free design featuring spark-proof technology and reverse polarity protection, but with enhanced thermal efficiency and power management to provide better performance and longer battery life.



www.a1batterypro.com.au



AUTO | MARINE | RV | POWERSPORT | LAWN & GARDEN



INTERFACE

POWER LED

The charger is in standby or the battery voltage is too low for the charger to detect.



FAST CHARGE

Illuminates white when fast charge is active. Fast charge LED turns red (solid/blinking) when there is an error.



REVERSE POLARITY

Charger is connected to the battery in reverse. Reverse the connections.



ERROR

Blinks "on" and "off" in various sequences (from 1 to 6 blinks) to convey error conditions.



COLD INDICATOR

Illuminates solid or flashes blue when internal temperature is too low.



CHARGE LED

Indicates the charge level of the internal battery.



HOT INDICATOR

Illuminates solid or flashes red when internal temperature is too high.



BOOST LED

Illuminates white when boost is active. The LED flashes white when manual override feature is active.



CHARGE DEVICES.

Power everything. With USB-C Power Delivery, you have the power to charge almost everything. Its internal power bank provides 60-watts of power—both in and out—to effortlessly power our favorite USB-C devices, like phones, tablets, laptops, wearables, and more.

RECHARGE TIME

28h	2.5W
14h	5W
7.2h	10W

TECHNICAL SPECIFICATIONS

INTERNAL BATTERY:	46 Wh Lithium Ion
PEAK CURRENT RATING:	1750A
OPERATING TEMPERATURE:	-4°F to +122°F (-20°C to +50°C)
CHARGING TEMPERATURE:	32°F to +104°F (0°C to +40°C)
USB-C (IN):	5V (1.5A/9V 3A/12V 3A/15V 3A/20V 3A)
USB-C (OUT):	5V (3A/9V 3A/12V 3A/15V 3A/20V 3A)
USB (OUT):	5VDC 2.1A Max / 10 W Max
HOUSING PROTECTION:	IP65 (w/Ports Closed)
COOLING:	Natural Convection
WEIGHT:	2.58 lbs (1.17kg)
LED FLASHLIGHT:	200 Lumens
VOLUMETRICS:	Retail Packaging: Dimensions: 3.94" x 6.34" x 9.13" Weight: 3.37 lbs UPC: 0-46221-20007-2
	Master Carton: Dimensions: 9.92" x 20.47" x 9.53" Weight: 22.64 lbs Quantity: 6 UCC: 10046221200079
	Inner Carton: Dimensions: 4.33" x 9.49" x 6.57" Weight: 3.57 lbs
	Units Per Pallet: 234 Units

WHAT'S IN THE BOX

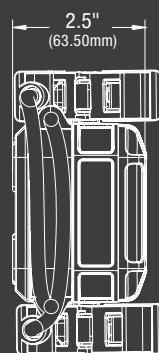
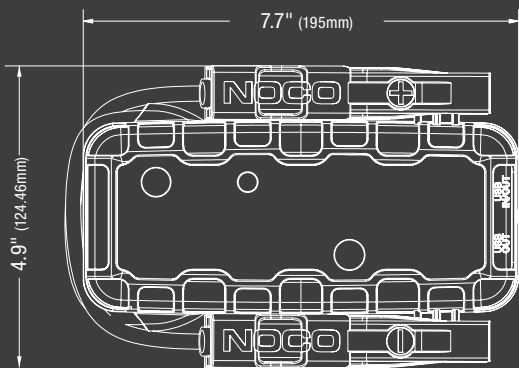

*Accessories not to scale with GBX55

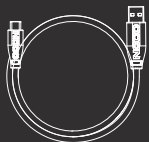

24in USB-A to USB-C Cable



User Guide

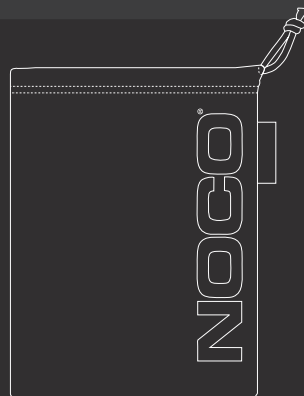

Microfiber Storage Bag



Two Great Stores to choose from...

7 Cemetery Rd,
Mackay QLD 4740
Phone 07 4957 6123

Unit 16, 547 Woolcock St,
Mt Louisa, Townsville QLD 4814
Phone 07 4774 7344