



USER MANUAL

AMPTRON BLUEEDGE DISPLAY

LCD 2.4 Inch Full Colour RS485 BMS Display

AT-BMSMON-2.4-COL-RS485-AV01



**We may modify these specifications without prior notice.*

p: 1300 543 376 | e: info@amptron.com.au | w: amptron.au



Thank you

Dear valued customer,
Thank you for choosing Amtron Products. We greatly appreciate your support. Our team works behind the scenes to create advanced battery systems, while providing top-notch Australian based service to our customers.

Support and feedback from our customers, along with the dedication of our staff, allows us to deliver exceptional products, competitive prices, and an overall excellent experience.

Thanks again for giving us your vote of confidence. We hope that you'll enjoy using our products as much as we've enjoyed creating them.

Please feel free to reach out to us anytime.

Sincerely,
Amtron



Product Registration

To ensure full coverage, visit our Amptron website at: <https://amptron.au/product-registration> and register your product within 60 days of purchase to activate the warranty.

Fill out the below information for your own record keeping:

Purchase Date:

Model:

Serial Number:

Vendor:

The latest warranty statement and additional warranty information can be found on our website by visiting: <https://amptron.au/warranties>



General Description

This colour LCD screen is a display accessory for Amtron's BluEdge Battery series. Simply connect the display to a BluEdge battery (or a bank of batteries that supports parallel communication) with a compatible communication cable to get an instant visual overview of the key status of your battery system. The display comes with built-in audible warning alarm for critical errors.

Key Features

- Quick, easy setup to display key battery information such as, State of Charge (% and Ah), Voltage, Current draw, Temperature, Cycles etc.
- Suitable for compliance with AS/NZS 3001.2:20222 and AS/NZS 3004.2:2014 standards.
- Built-in audible alarm that will trigger on adverse battery conditions prior to battery shut-down.
- Conveniently view any battery alarm codes.
- Easy installation with common cables, for remote battery monitoring with flexible flush mounted design.
- View consolidated battery information for a bank/group of connected batteries in one display (for models that supports parallel communication), dive into detailed cell data for each connected battery in the group.

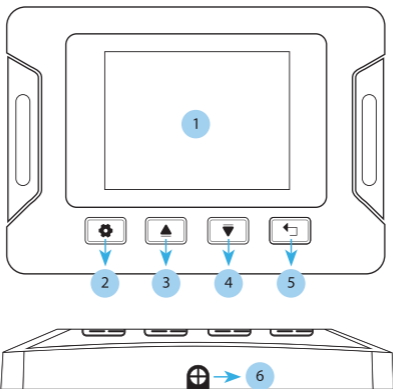

1	LCD Main Screen	4	Down Key
2	Setting / Enter	5	Return / Back Key
3	Up Key	6	RS-485 Wiring Hole



Dimensions (mm)

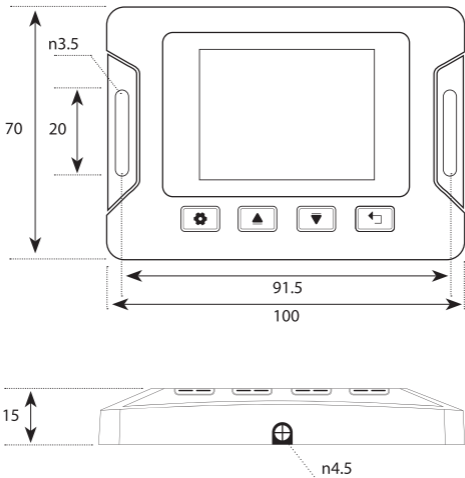



Mounting Instructions

There are two ways to mount the display. The monitor can be mounted directly to a wall, without a cavity behind it.

In this example, the wire can be routed to run through the bottom of the display, allowing a flush-mount to the surface.

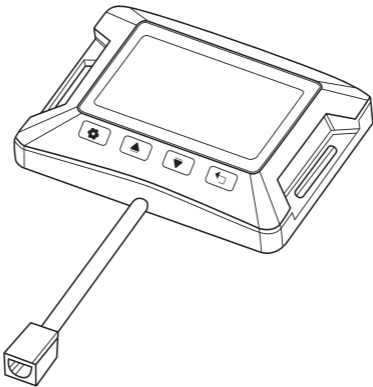



Mounting Instructions *Cont.*

In the second example, the monitor is installed on a wall with a cavity behind it. In this case a hole can be drilled (30mm diameter) allowing the RS485 port to be pushed into the recess to allow hidden connection to the equipment.

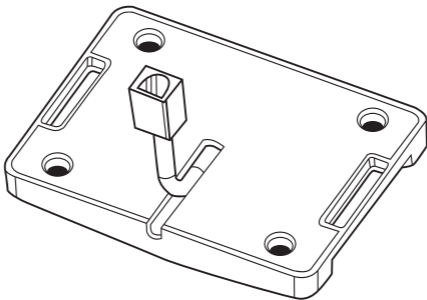

**** Must be installed in a dry location.**



Protocol Selection

The BluEdge monitor has different protocols available. The choice of protocol depends on your battery model and/or configuration (single battery, batteries connected in parallel or batteries connected in series).

When connecting the monitor, or turning on the battery, the following selection screen will be presented:

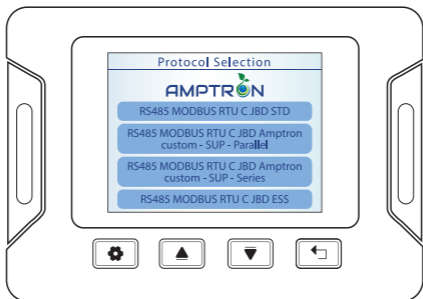



Protocol Selection *Cont.*

Use the ▲ and ▼ arrows to select the correct protocol and the ⚙ icon to select the chosen protocol.

Please consult your battery user manual for the applicable protocol to select for your battery(s), or head to our website for the latest mapping of protocols to use for each battery model:

<https://amptron.au/product/lcd-2-4-inch-full-colour-rs485-bluedge-bms-display>



Screen Detailed Descriptions

RS485 MOBUS RTU-JBD STD (Protocol 1)

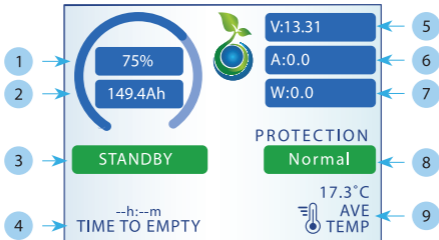



1	SOC (State Of Charge)	6	Battery Amperage (charge/discharge)
2	Remaining Capacity (Ah)	7	Battery Wattage
3	Status (standby/charge discharge)	8	Battery Status Normal/ Alarm (see alarm list)
4	Time To Empty (time until depletion)	9	Battery Average Temp (averaged across 3 sensors)
5	Battery Voltage		



RS485 MOBUS RTU-JBD STD (Protocol 1) Cont.

1 →  DSG CHG 2

149.4Ah 0000 3
75% Cycles

1 →  MinCellV:3.328  MinT: 13.1°C 4
MaxCellV:3.330 MaxT: 19.2°C

PROTECTION STATUS **Normal** 5

1	Min/Max Cell Voltages	4	Min/Max Cell Temperature
2	MOSFET State	5	Battery State Normal/ Alarm
3	Total Cycle Count		



RS485 MOBUS RTU-JBD Custom-SUP-Parallel (Protocol 2)

RS485 MOBUS RTU-JBD Custom-SUP-Series (Protocol 3)

Home Screen / Screen 1

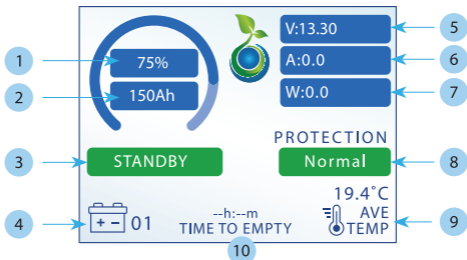

1	Averaged SOC (State Of Charge)	6	Averaged Battery Amperage
2	Remaining Capacity (Ah)	7	Averaged Battery Wattage (charge/discharge)
3	Status (standby/charge/discharge)	8	Battery Status Normal/ Alarm (see alarm list)
4	No# Batteries in Group/Online	9	Battery Average Temp (averaged across 3 sensors)
5	Averaged Battery Voltage	10	Time To Empty (time until depletion)

Detailed Information / Screen 2

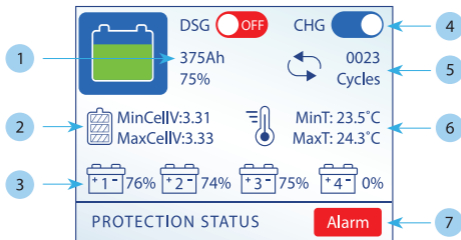

1	Remaining Total Capacity (Ah)	5	Total Cycle Count
2	Min/Max Cell Voltages (master battery)	6	Min/Max Cell Temperature
3	Group of Batteries SOC Overview	7	Battery State Normal/ Alarm (see alarm list)
4	MOSFET State		



Alarm Screen (Protocol 1/2/3)

RS485 MOBUS RTU-JBD STD

RS485 MOBUS RTU-JBD Amtron custom-SUP-Parallel

RS485 MOBUS RTU-JBD Amtron custom-SUP-Series

Screen 3 in **protocol 1,2,3** appears as below:

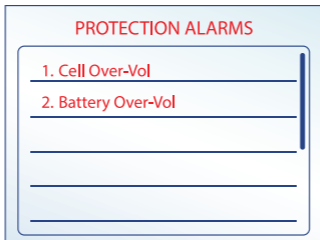

Please see our website for the latest error codes and descriptions of what this means in relation to the BluEdge Batteries.

Website: <https://amtron.au/info/bluedgerange>

RS485 MOBUS RTU-JBD ESS (Protocol 4)

Home Screen / Screen 1

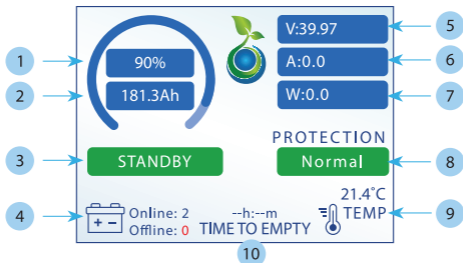

1	Averaged SOC (State Of Charge)	6	Averaged Battery Amperage (charge/discharge)
2	Remaining Total Capacity (Ah)	7	Averaged Battery Wattage (charge/discharge)
3	Status (standby/charge discharge)	8	Battery Status Normal/ Alarm (see alarm list)
4	No# Batteries in Group/Online	9	Battery Average Temp (averaged across battery bank)
5	Averaged Battery Voltage	10	Time To Empty (time until depletion)

Detailed Information / Screen 2

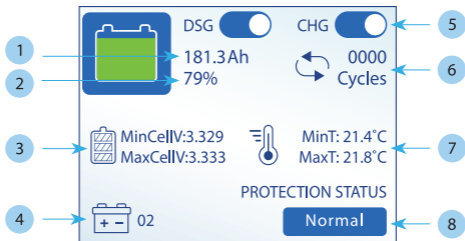

1	Remaining Total Capacity (Ah)	5	MOSFET State
2	Averaged SOC (State Of Charge)	6	Total Cycle Count
3	Min/Max Cell Voltages (total pack)	7	Min/Max Cell Temperature
4	No# Batteries in Group/Online	8	Battery State Normal/Alarm (see alarm list)



RS485 MOBUS RTU-JBD ESS (Protocol 4) Cont.

Select Battery Module / Screen 3

Use the ▲ and ▼ arrows to select the battery and the ⚙ button to enter the detailed information.

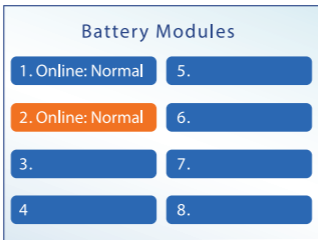

Detailed Battery Module Information / Screen 4

Use the ▲ and ▼ arrows to select the cells, voltage or temp icon and the ⚙ button to enter the detailed information.

The detailed screens for cells, voltage and temp are shown on pages 20, 21 & 22.

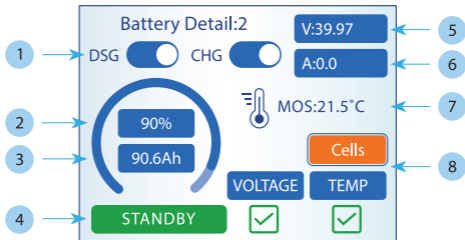

1	MOSFET State	5	Battery Voltage
2	Averaged SOC (State Of Charge)	6	Battery Amperage
3	Remaining Module Total Capacity (Ah)	7	BMS MOSFET Temp
4	Status (standby/charge/discharge)	8	Cells, Voltage & Temp Icons (click for detailed info)



RS485 MOBUS RTU-JBD ESS (Protocol 4) Cont.

Individual Cell Voltages Of Selected Module / Screen 5

Battery Cells 2	
1. 3.331 V	5. 3.332 V
2. 3.331 V	6. 3.331 V
3. 3.331 V	7. 3.332 V
3. 3.330 V	8. 3.331 V



RS485 MOBUS RTU-JBD ESS (Protocol 4) Cont.

Selected Module Temp and Voltage Alarms/ Screen 6

Bat 2: Vol Protection State

The screenshot shows a light blue rectangular window with a title bar at the top that reads "Bat 2: Vol Protection State" in red text. Below the title bar is a scrollable area containing five horizontal lines, representing a list of data or status entries. A vertical scrollbar is visible on the right side of the scrollable area.



RS485 MOBUS RTU-JBD ESS (Protocol 4) Cont.

Selected Module Temp and Voltage Alarms/ Screen7

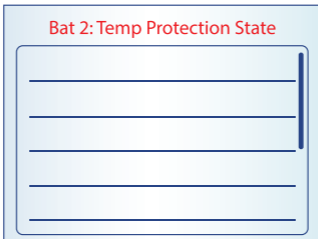

Please see our website for the latest error codes and descriptions of what this means in relation to BluEdge Batteries.

amptron.au/info/bluedgerange



Notes:



© **Ampron Technology Group 2024**

Any use in full or in part of this user manual must include attribution.